



BY GORMAN-RUPP®

Engine Driven Portable Trash Pump

Die-Cast Aluminum or Cast Iron, Self-Priming Engine Driven Pumps with B&S or Honda Gasoline or Yanmar Diesel Engine

- *Horsepower 5.5 to 6.5*
- *Suction and Discharge Port Sizes: 2" and 3"*
- *Die-Cast Aluminum or Cast Iron*
- *Max. Flow: 180 to 300 GPM*
- *Max. Head: 103 to 110 ft.*
- *Max. Lift: 26 ft.*
- *Max. Solids Handling: 2S5- 1" 3S5- 1.25"*
- *Silicon-Carbide Seal with Dry Run Survivability*
- *Quick Clean Out*
- *Optional Viton® Elastomers*
- *Optional Wheel Kit*



Model 3S5IR

High-volume self-priming centrifugal trash pumps come standard with a ductile iron impeller to resist abrasion and "T" handles for easy access. All pumps feature stainless steel internal hardware, built-in check valve, integral built-in carry handle, suction strainer and rubber feet. Standard with male NPT threads. All models (except Honda and Yanmar powered models) carry "Made in USA" Labeling.

*Viton® is a registered trademark of DuPont

COMMERCIAL DUTY

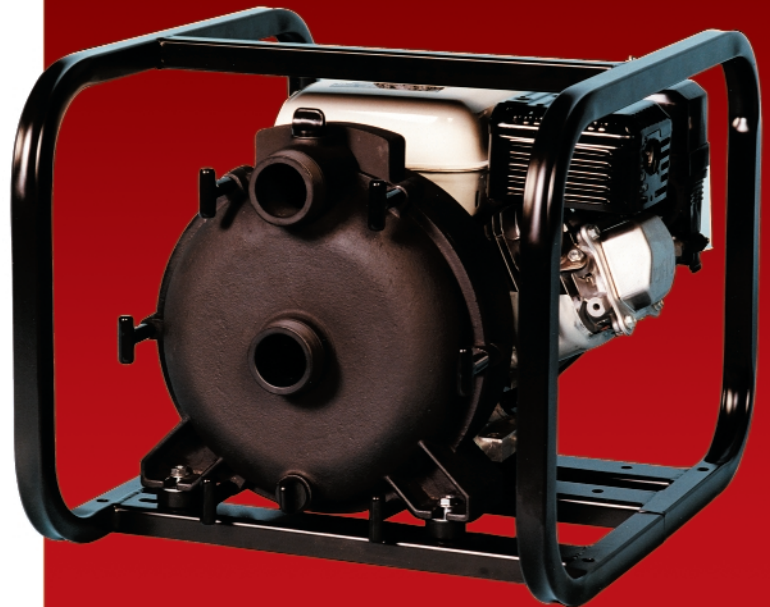

Model 2S5HCR

Performance of Trash Pump

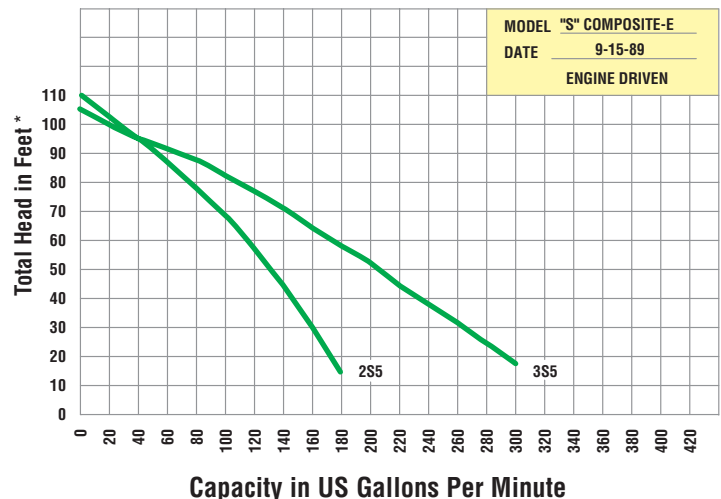

*Convert to PSI, divide by 2.31

Liquid-Water specific gravity 1.0

Portable Trash Pump

2" Solids Handling Pumps

Alum. Model #	Alum. Ship Wt. (lbs.)	Cast Iron Model #	Cast Iron Ship Wt. (lbs.)	Driver Type & HP	Seal Type & Elastomer/Faces	Tank Size (Qts.)	Run Time	Mounting
2S5AR	83	2S5ACR	105	B&S 5.5 hp OHV	Viton®*/Sic/Sic	3	1.4	Roll Cage
2S5IR	91	2S5ICR	113	B&S 6.5 hp PRO	Viton®*/Sic/Sic	4	2	Roll Cage
2S5HR	87	2S5HCR	109	Honda 5.5 hp	Viton®*/Sic/Sic	3.88	2	Roll Cage
2S5YR	108	2S5YCR	130	Yanmar 4.7 hp	Viton®*/Sic/Sic	2.6	1.8	Roll Cage

3" Solids Handling Pumps

Alum. Model #	Alum. Ship Wt. (lbs.)	Cast Iron Model #	Cast Iron Ship Wt. (lbs.)	Driver Type & HP	Seal Type & Elastomer/Faces	Tank Size (Qts.)	Run Time	Mounting
3S5AR	92	3S5ACR	114	B&S 5.5 hp OHV	Viton®*/Sic/Sic	3	1.4	Roll Cage
3S5IR	100	3S5ICR	122	B&S 6.5 hp PRO	Viton®*/Sic/Sic	4	2	Roll Cage
3S5HR	96	3S5HCR	118	Honda 5.5 hp	Viton®*/Sic/Sic	3.88	2	Roll Cage
3S5YR	117	3S5YCR	139	Yanmar 4.7 hp	Viton®*/Sic/Sic	2.6	1.8	Roll Cage

5/8 Threaded Kit (Single)

Alum. Model #	Alum. Ship Wt. (lbs.)	Cast Iron Model #	Cast Iron Ship Wt. (lbs.)	Seal Type & Elastomer/Faces	Mounting
2S5	36	2S5C	36	Viton®*/Sic/Sic	Handle
3S5	42	3S5C	42	Viton®*/Sic/Sic	Handle

*Viton® is a registered trademark of DuPont

Standard Features

- > Ductile Iron Impeller
- > Quick Release Handles and Cast Iron Volute
- > Silicon Carbide, Self-Lubricated Seal with Graphite Impregnated Seat and Viton® Elastomers
- > Built-In Carrying Handle
- > Large Pump Casing
- > Built-In Check Valve
- > Horizontal Discharge and Male Threaded Connections
- > Choice of Briggs & Stratton Standard or Premium, Honda gas or Yanmar diesel
- > Optional Wheel Kit
- > Strainer Supplied
- > Rubber Foot Mounting
- > Optional Viton®* Elastomers

WARNING: Do not use in explosive atmosphere or for pumping volatile flammable liquids.

Viton® Elastomers including O-rings and check valve.

Two wheel truck assemblies with semi-pneumatic tires for pumps with roll cages.

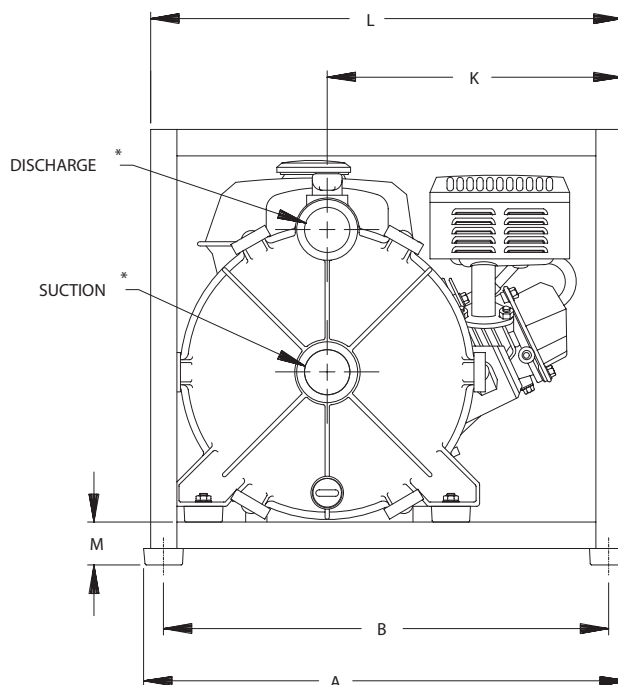
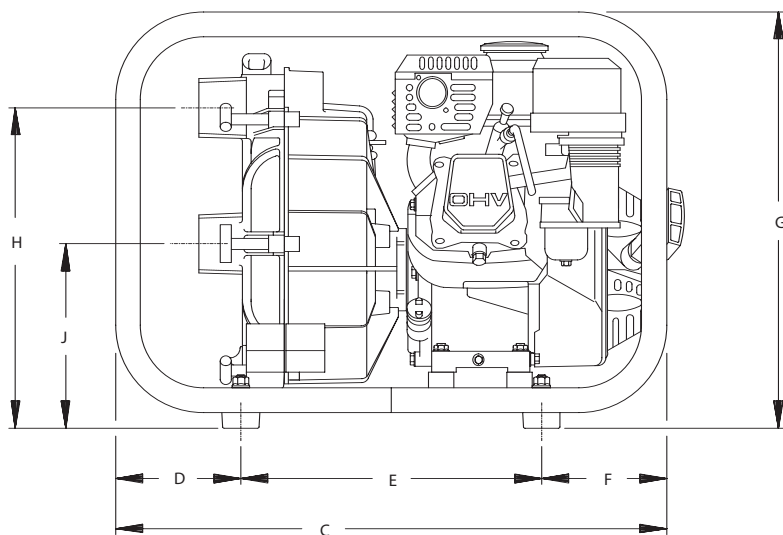

DIMENSIONS:
INCHES
[MILLIMETERS]

MODEL	A	B	C	D	E	F	G	H	J	K	L	M	DISCH *	SUCT *
2S5	18.50 [469,9]	17.00 [431,8]	25.00 [635,0]	5.00 [127,0]	15.00 [381,0]	5.00 [127,0]	16.62 [422,1]	12.75 [323,8]	7.25 [184,2]	11.25 [285,8]	18.00 [457,2]	1.62 [41,1]	2.00	2.00
3S5	18.50 [469,9]	17.00 [431,8]	25.00 [635,0]	5.00 [127,0]	15.00 [381,0]	5.00 [127,0]	16.62 [422,1]	13.40 [340,4]	7.38 [187,4]	11.36 [288,5]	18.00 [457,2]	1.62 [41,1]	3.00	3.00

(*) STANDARD NPT (MALE) PIPE THREAD

TRASH PUMPS
0255HR